



AD-333
Service Manual
Phase 5
Microprocessor Controls

American Dryer Corporation
88 Currant Road
Fall River MA 02720-4781 USA
Telephone: +1 (508) 678-9000 / Fax: +1 (508) 678-9447
e-mail: techsupport@amdry.com

www.adclaundry.com

Retain This Manual in a Safe Place for Future Reference

This product embodies advanced concepts in engineering, design, and safety. If this product is properly maintained, it will provide many years of safe, efficient, and trouble free operation.

Only qualified technicians should service this equipment.

OBSERVE ALL SAFETY PRECAUTIONS displayed on the equipment or specified in the installation manual included with the dryer.

The following **“FOR YOUR SAFETY”** caution must be posted near the dryer in a prominent location.

FOR YOUR SAFETY

Do not store or use gasoline or other flammable vapors and liquids in the vicinity of this or any other appliance.

POUR VOTRE SÉCURITÉ

Ne pas entreposer ni utiliser d'essence ni d'autres vapeurs ou liquides inflammables à proximité de cet appareil ou de tout autre appareil.

We have tried to make this manual as complete as possible and hope you will find it useful. The manufacturer reserves the right to make changes from time to time, without notice or obligation, in prices, specifications, colors, and material, and to change or discontinue models. The illustrations included in this manual may not depict your particular dryer exactly.

IMPORTANT

For your convenience, log the following information:

DATE OF PURCHASE _____ MODEL NO. **AD-333**

RESELLER'S NAME _____

SERIAL NUMBER(S) _____

Replacement parts can be obtained from your reseller or the ADC factory. When ordering replacement parts from the factory, you can FAX your order to ADC at +1 (508) 678-9447 or telephone your order directly to the ADC Parts Department at +1 (508) 678-9000 or contact parts@amdry.com. Please specify the dryer model number and serial number in addition to the description and part number, so that your order is processed accurately and promptly.

“IMPORTANT NOTE TO PURCHASER”

Information must be obtained from your local gas supplier on the instructions to be followed if the user smells gas. These instructions must be posted in a prominent location near the dryer.

IMPORTANT

You must disconnect and lockout the electric supply and the gas supply or the steam supply before any covers or guards are removed from the machine to allow access for cleaning, adjusting, installation, or testing of any equipment per OSHA standards.

Please observe all safety precautions displayed on the equipment and specified in the installation and operator's manual included with the dryer.

FOR YOUR SAFETY

Do not store or use gasoline or other flammable vapors and liquids in the vicinity of this or any other appliance.

Do not dry mop heads in the dryer.

Do not use dryer in the presence of dry cleaning fumes.

CAUTION

Dryers should never be left unattended while in operation.

WARNING

Children should not be allowed to play on or near the dryers.

Children should be supervised if near dryer(s) in operation.

The dryer must never be operated with any of the back guards, outer tops, or service panels removed. Personal injury or fire could result.

The dryer must never be operated without the lint filter or screen in place, even if an external lint collection system is used.

The dryers must not be installed or stored in an area where it will be exposed to water or weather.

The wiring diagram for the dryer is located in the front electrical control box area.

Table of Contents

Safety Precautions	5
Routine Maintenance	5
Cleaning	5
Adjustments	5
Lubrication	5
Installation Requirements	6
Enclosure Air Supply and Exhaust Requirements	6
Electrical and Gas Requirements	6
Operational Service Check Procedure	6
Description of Parts	7
Control Panel (Microprocessor)	7
Main Door Switch and Front Panel	7
Lint Drawer	7
Lint Box and Door and Switch and Temperature Sensor Assembly	8
Tumbler	8
Tumbler Bearing and Pulley Arrangement	8
Idler Bearing	8
Drive Motor and Impellor	9
Gas Burner	9
Sail Switch	9
Electrical Panel	9
Service	10
Controls (Computer)	10
Thermostats and Temperature Sensor	13
Sail Switch Assembly	13
Front Panel and Main Door Assemblies	14
Tumbler and Bearing Assembly	15
Idler and Bearing Assembly	15
Drive Pulley	16
Tumbler	16
V-Belts	17
Motor	17
Impellor	17
Lint Screen	18
List of Acronyms	
DSI Direct Spark Ignition	
L.E.D. Light Emitting Diode	
L.P. Liquid Propane	
OSHA Occupational Safety and Health Administration	

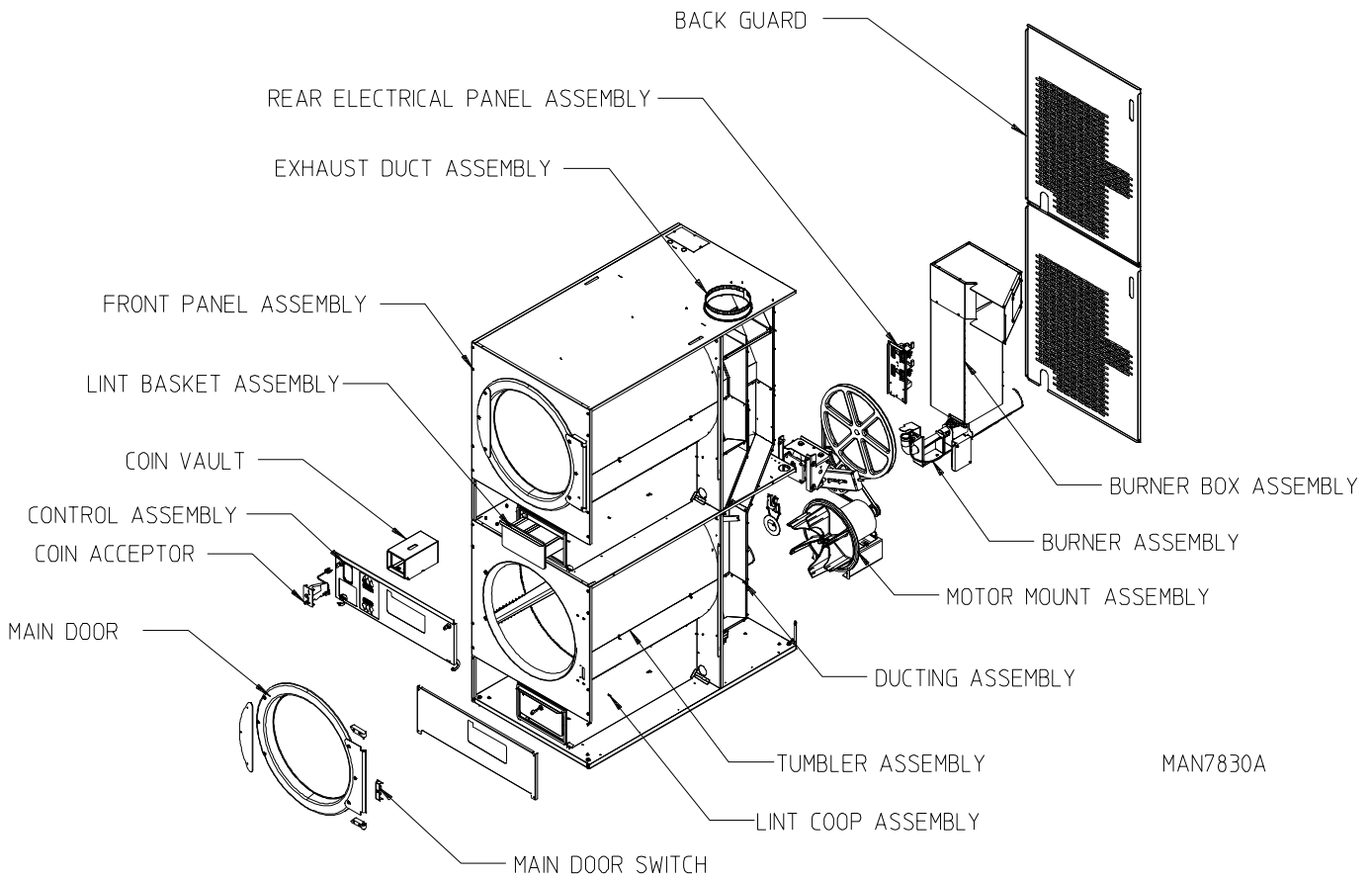

MAN7830A

Safety Precautions

Do not store or use gasoline or other flammable vapors and liquids in the vicinity of this or any other appliance.

Purchaser and/or user should consult the local gas supplier for proper instructions to be followed in the event the user smells gas. The instructions should be posted in a prominent location.

Dryer(s) must be exhausted to the outdoors.

Although ADC produces a very versatile dryer, there are some articles that due to fabric composition or cleaning method should not be dried in it.

WARNING: Dry only water washed fabrics. Do not dry articles spotted or washed in dry cleaning solvents, a combustible detergent, or "all purpose" cleaners. Explosion could result.

Do not dry rags or articles coated or contaminated with gasoline, kerosene, oil, paint, or wax. Explosion could result.

Do not dry mop heads. Contamination by wax or flammable solvents will create a fire hazard.

Do not use heat for drying articles that contain plastic, foam, sponge rubber, or similarly textured rubberlike materials. Drying in a heated tumbler may damage plastics or rubber and may be a fire hazard.

A program should be established for the inspection and cleaning of lint in the burner area and exhaust ductwork. The frequency of inspection and cleaning can best be determined from experience at each location.

WARNING: The collection of lint in the burner area and exhaust ductwork can create a potential fire hazard.

For personal safety, the dryer must be electrically grounded in accordance with local codes and/or the National Electrical Code ANSI/NFPA NO. 70-LATEST EDITION or in Canada, the Canadian Electrical Codes Parts 1 & 2 CSA C22.1-1990 or LATEST EDITION.

Under no circumstances should the dryer door, lint drawer switches or heat safety devices ever be disabled.

Read and follow all caution and direction labels attached to the dryer.

WARNING: Children should not be allowed to play on or in the dryers. Children should be supervised if near dryers in operation.

Routine Maintenance

Cleaning

A program and/or schedule should be established for periodic inspection, cleaning, and removal of lint from various areas of the dryer, as well as throughout the ductwork system. The frequency of cleaning can best be determined from experience at each location. Maximum operating efficiency is dependent upon proper air circulation. The accumulation of lint can restrict this airflow. If the guidelines in this section are met, an ADC dryer will provide many years of efficient, trouble free and most importantly safe operation.

WARNING: Lint from most fabrics is highly combustible. The accumulation of lint can create a potential fire hazard.

Suggested Interval

Daily

Clean lint screen. Inspect lint screen and replace if damaged.

90 Days

Remove lint accumulation from lint chamber thermostats and sensors.

WARNING: To avoid the hazard of electrical shock, discontinue electrical supply to the dryer.

Remove lint from the motor air vents and surrounding area.

Inspect and tighten all setscrews (i.e.; pulleys, idler bearings, tumbler bearings).

IMPORTANT: Lint accumulation will restrict internal motor airflow, causing overheating and irreparable damage. Motor failure due to lint accumulation will void the warranty.

120 Days

Remove lint from gas burner area with dusting brush or vacuum cleaner attachment.

6 Months

Inspect and remove lint accumulation in the customer-furnished exhaust ductwork system. Inspect exhaust back draft dampers to ensure that they are not binding. Inspect and remove all lint accumulation from in and around control box area including coil acceptors. Clean lint accumulation from around tumbler wrapper area.

IMPORTANT: The accumulation of lint in the exhaust ductwork can create a potential fire hazard.

As Required

In cleaning and care of the cabinet, avoid using harsh abrasives. A product intended for the cleaning of appliances is recommended.

Adjustments

6 Months

Motor and drive belts should be examined. Cracked or seriously frayed belts should be replaced. Tighten loose belts when necessary, and check belt alignment.

Complete operational check of controls and valves.

Complete operational check of all safety devices (door switches, sail switch, burner and lint chamber thermostats).

12 Months

Inspect bolts, nuts, screws, nonpermanent gas connections, (unions orifices, etc.) electrical terminals, and grounding connections.

Lubrication

The new bearings, idler bearings and tumbler bearing are sealed, lubrication is not necessary.

Installation Requirements

Installation should be performed by competent technicians in accordance with local and state codes. In the absence of these codes, the installation must conform to applicable American National Standards: ANSI Z223.1-LATEST EDITION (National Fuel Gas Code) or ANSI/NFPA NO. 70-LATEST EDITION (National Electrical Code) or in Canada, the installation must conform to applicable Canadian Standards: CAN/CGA-B149.1-M91 (Natural Gas) or CAN/CGA-B149.2-M91 (L.P. Gas) or LATEST EDITION (for General Installation and Gas Plumbing) or Canadian Electrical Codes Parts 1 & 2 CSA C22.1-1990 or LATEST EDITION (for Electrical Connections).

Enclosure Air Supply and Exhaust Requirements

NOTE: The following information is very brief and general. For a detailed description refer to the installation booklet for coin machines.

Bulkheads and partitions around the dryer should be made of noncombustible materials. Allowances should be made for the opening and closing of the control door and lint door. Also, allowances should be made in the rear for ease of maintenance. (Refer to installation manual for recommended distances and minimum allowances required.)

When the dryer is operating, it draws in room air, heats it, passes this air through the tumbler and exhausts it out the building. Therefore, the room air must be continually replenished from the outdoors. If the make up air is inadequate, drying time and drying efficiency will be adversely affected. Also, on gas machines ignition problems and sail switch "fluttering" problems may result and on a electric machine, premature electric element failure may result. Air supply must be given careful consideration to insure proper performance of each dryer.

IMPORTANT: Make-up air must be provided from a source free of dry cleaning fumes. Make-up air that is contaminated by dry cleaning fumes will result in irreparable damage to motors and other dryer components.

Exhaust ductwork should be designed and installed by a competent technician. Improperly sized ductwork will create excessive back pressure, which will result in slow drying, increased use of energy, and shut down of the burner by the air flow (sail) switch. Refer to Installation Manual for more details.

CAUTION: Improperly sized, installed or maintained (cleaned) exhaust ductwork creates a potential fire hazard.

Electrical and Gas Requirements

It is your responsibility to have all electrical connections made by a properly licensed and competent electrician to assure that the electrical installation is adequate and conforms to local and state regulations or codes. In the absence of such codes, all electrical connections, materials, and workmanship must conform to the applicable requirements of the National Electrical Code ANSI/NFPA NO. 70-LATEST EDITION or in Canada, the Canadian Electrical Codes Parts 1 & 2 CSA C22.1-1990 or LATEST EDITION.

IMPORTANT: Failure to comply with these codes or ordinances, and or the requirements stipulated in this manual, can result in personal injury or component failure.

The dryer installation must meet the American National Standard, National Fuel Gas Code ANSI Z223.1 (latest edition), as well as, local codes and ordinances and must be done by a qualified technician.

NOTE: Undersized gas piping will result in ignition problems and slow drying and can create a safety hazard.

The dryer must be connected to type of gas (natural or L.P.) indicated on the dryer data label. If this information does not agree with the type of gas available, contact the distributor who sold the dryer or contact the factory.

The gas input ratings shown on the dryer data label are for elevations up to 2,000 feet, unless elevation requirements of over 2,000 feet were specified at the time the dryer order was placed with the factory. The adjustment for dryers in the field for elevations over 2,000 feet are made by changing the burner orifices. If this adjustment is necessary contact the distributor's who sold the dryer or contact the factory.

NOTE: Any burner changes must be made by a qualified technician.

Operational Service Check Procedure

After performing any service or maintenance function, an operational check should be performed to ensure that all components are performing properly.

Make a complete operational check of all the operating controls to ensure that the timing is correct, temperature selection switches are functioning properly.

Make a complete operational check of all safety related circuits, door switch(es), hi-limit thermostat, sail switch, cycling thermostats, etc.

Description of Parts

Control Panel (Microprocessor)

Opening the control door will reveal the control panel assembly. Opening the control panel will allow access to the major components, which include the coin acceptor, computer board, and keypad. The coin acceptor sends the signal to the computer that a coin has been inserted. The keypad inputs to the computer what temperature has been selected. The computer controls the entire operation of the machine. It accepts inputs and send outputs to various parts throughout the machine.

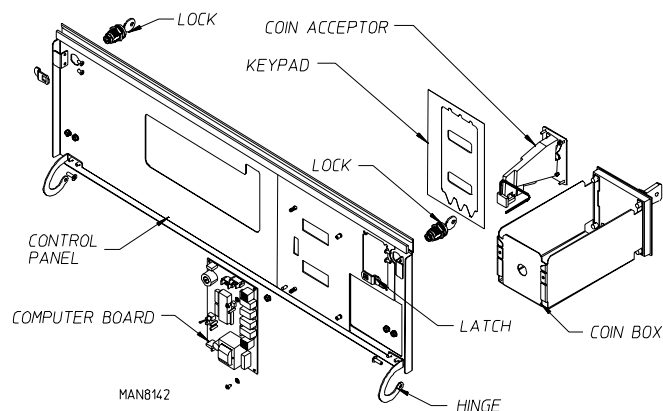

Electrical Panel

The control panel is made up of 2 motor contactors, fuse(s), and a 24VAC transformer. The fuse(s) protect the transformer from shorting. The transformer is used to break the incoming voltage to 24VAC for the control voltage of the machine. The motor contactor is used to drive the motor when the computer applies voltage to the contactors coil.

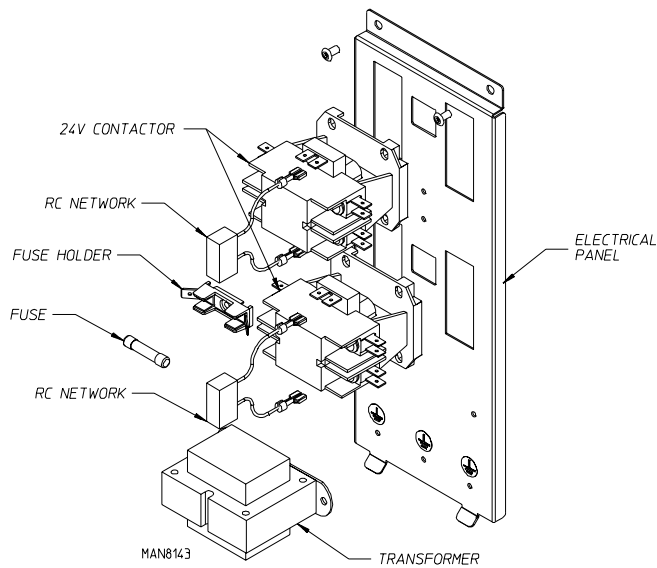

Main Door Switch and Front Panel

The main door switch is located behind the main door on the right-hand side. When the main door is opened, the switch will also open preventing the dryer from operating. The main door switch is a safety device and should never be disabled.

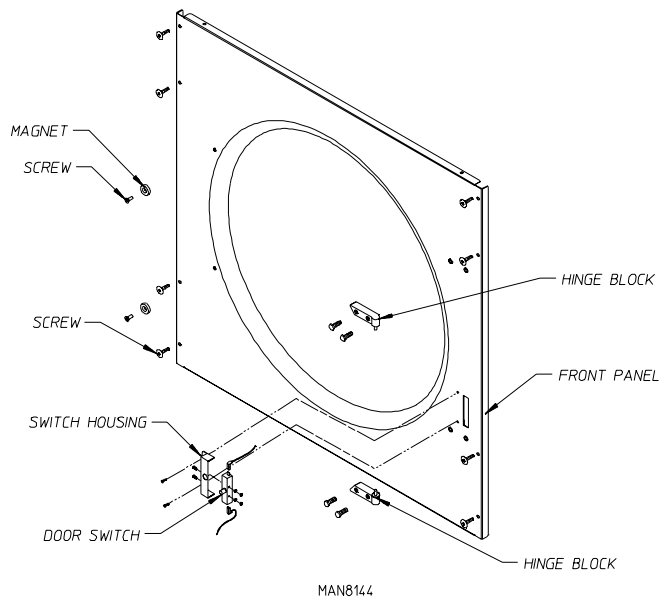

Lint Drawer

The lint screen is located just below the tumbler. The lint screen prevents lint from entering the exhaust system. The lint screen should be kept clean at all times. Lint screens with tears or holes should be replaced immediately. This type lint screen should be clean after every load.

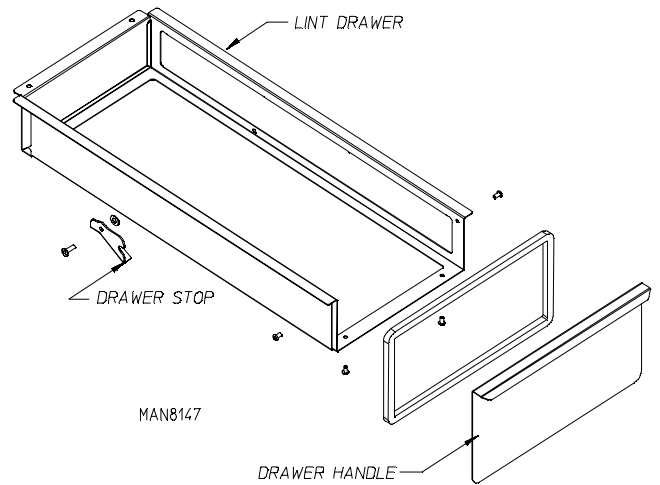

Lint Box, Lint Switch, and Temperature Sensor Assembly

The lint box is located just below the tumbler. The temperature sensor assembly is inside lint compartment on the left-hand side. The lint switch is located at the top left front of the lint box.

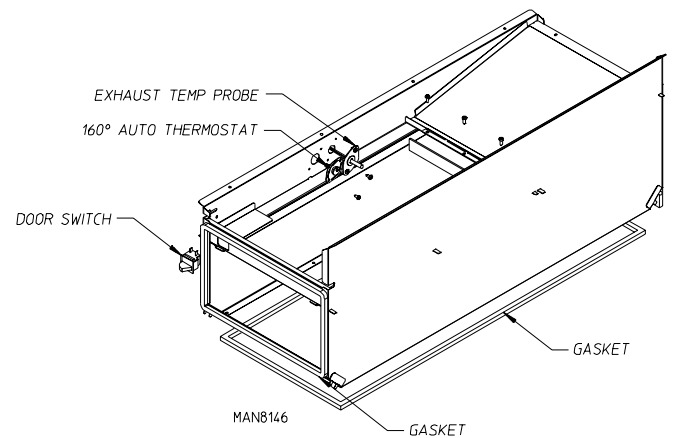

When the lint switch is opened, the dryer will not operate and if a restart is attempted with the switch open, the computer will display, "DOOR".

Tumbler

The tumbler consists of three ribs and a perforated basket along with a front and back, which are riveted together as an assembly. The tumbler also consists of tie rods, which attach the tumbler to the drive system in the rear. The felt collar helps to keep lint from accumulating behind the basket.

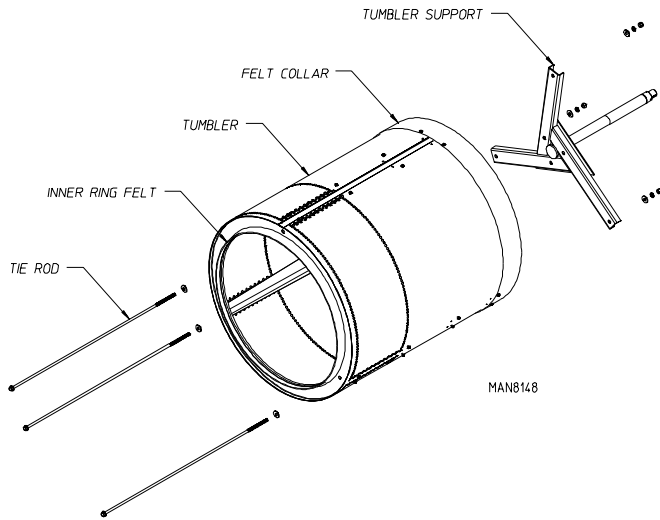

Tumbler Bearing and Pulley Arrangement

The tumbler bearing and the pulley arrangement is located (viewing from the rear of the dryer) approximately at the upper center of the dryer. The arrangement consists of a pulley, bearing box, and bearings, which serve to adjust, drive, and support the tumbler. The bearing box has various nuts and bolts that are made to adjust the basket vertically and horizontally.

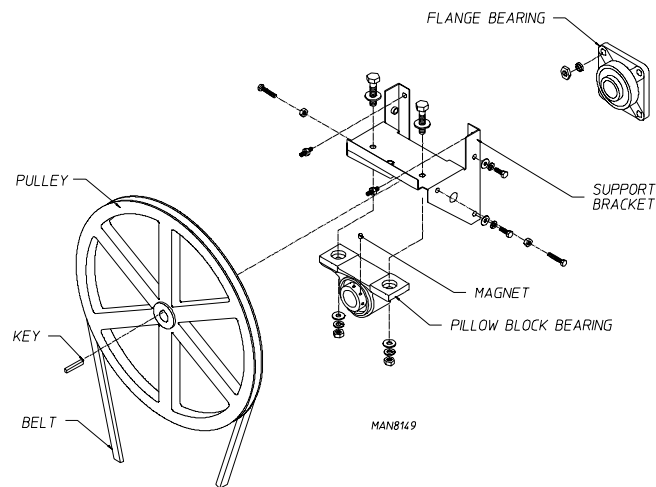

Idler Bearing

(Viewing from the rear of the dryer) The idler assembly is located approximately on the lower left hand-side of the dryer. The idler assembly consists of a shaft, bearings, and compound pulley. The idler's main purpose is to reduce the speed and increase torque provided to the tumbler. Also, the idler assembly allows for adjustment (tensioning) of the belts.

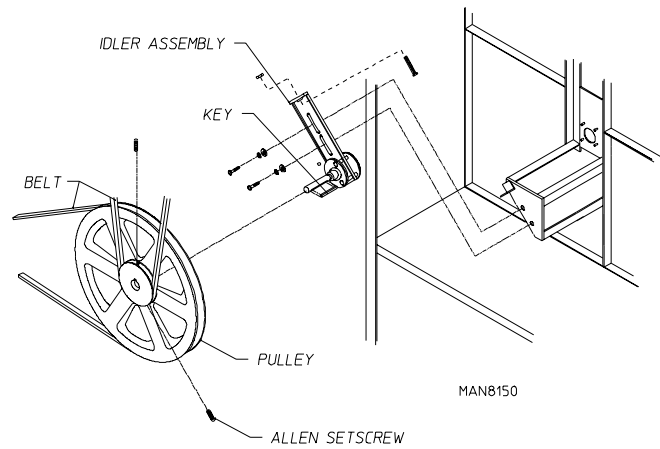

Drive Motor and Impellor

The drive motor is located on the back, approximately lower left-hand side of the dryer. It sits on an adjustable base so the motor can easily be adjusted to the left or right, in or out. The threaded shaft of the motor is connected to the impellor, a backward curved paddlewheel. The impellor provides airflow in the dryer. It creates a vacuum, which pulls the hot air from the burner into the basket through the lint screen and out the exhaust.

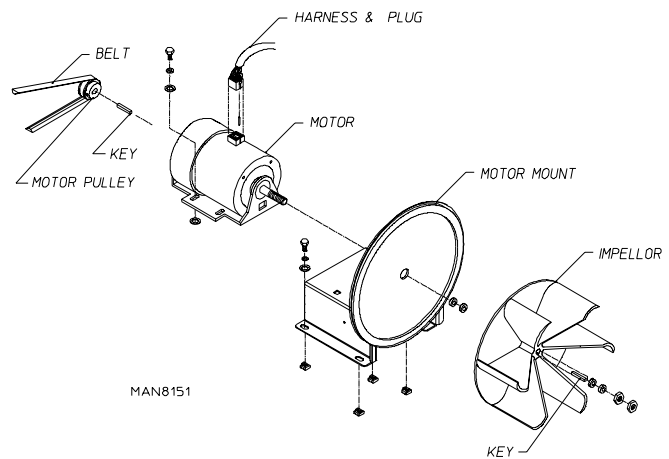

Gas Burner

The gas burner assembly consists of the burner tube, orifice (the orifice has a hole in it to allow gas to flow through. The hole size varies with different elevations, and different BTUs), gas valve (which can be set up for natural gas or L.P.), spark ignitor and probe assembly, DSI module, and flame spreader.

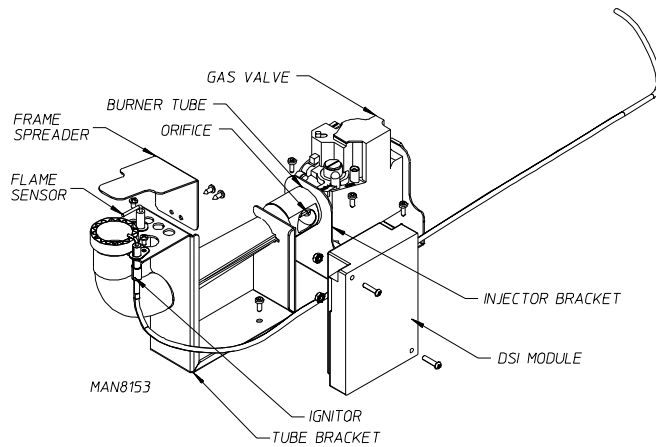

Sail Switch

The sail switch consists of a round plate on a lever arm, which acts like an actuator for a micro-switch. When the blower motor comes on, it draws air from the burner. This creates a negative pressure inside the basket area, and this negative pressure pulls in the round damper, which activates the sail switch. If there is improper airflow, the damper will not pull in, preventing the burner from coming on. Improper airflow can be caused by improperly designed exhaust ducting, where the duct run is too long or has too many sharp bends in it. It can also be caused by a lack of make-up air.

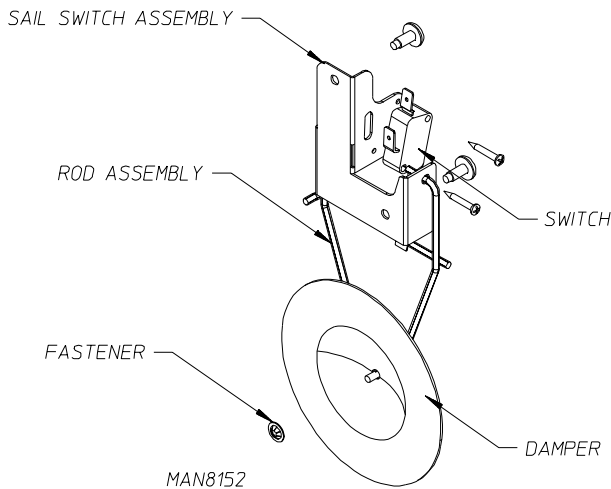

Electrical Panel

The electrical panel is located at the back of the machine at the center left. The panel includes two contactors, a transformer, and fuse(s). The purpose of the contactors is to provide line voltage to the motors once the low voltage signal is received at the coil. The purpose of the transformer is to provide a low voltage power source for the control circuits. The fuse(s) are to protect the transformer.

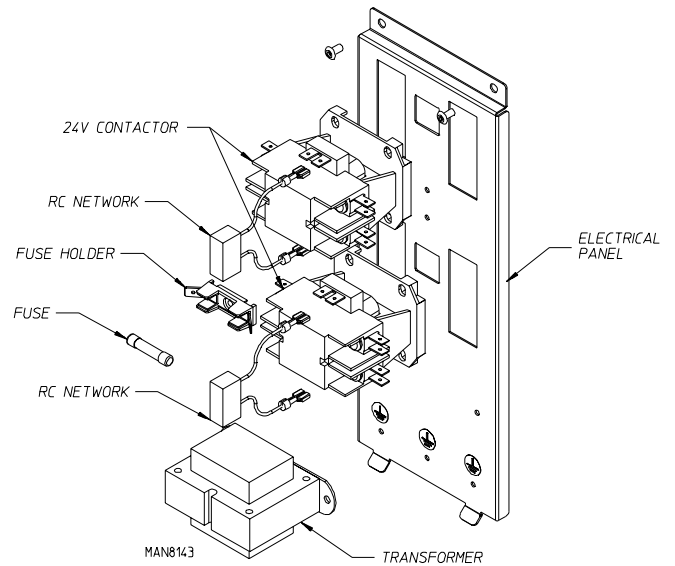

Service

All electrical/mechanical service or repairs should be made with the electrical power to the dryer disconnected (power off).

WARNING: Personal injury could result.

The information provided in this section should not be misconstrued as a device for use by untrained persons making repairs. Service work should be performed by competent technicians in accordance with local state and federal codes. When contacting the factory for assistance, always have the dryer model and serial numbers available.

CAUTION: Observe all safety precautions displayed on the dryer or specified in this manual before and while making repairs.

IMPORTANT: The information provided will help isolate the most probable component(s) associated with the difficulty described. The experienced technician realizes, however, that a loose connection or broken/shorted wire may be at fault where electrical components are concerned ... not necessarily the suspected component itself. Electrical parts should always be checked for failure before being returned to the factory.

You must disconnect and lockout the electric supply and the gas supply before any covers or guards are removed from installation, or testing of any equipment per OSHA standards.

Controls (Computer)

To Replace Computer

1. Disconnect power to dryer.
2. Open control door (2 locks to access computer panel).
3. Disconnect main power harnesses from the rear of the computer by squeezing the top locking tab and pulling the connector straight back.
4. Disconnect the green ground wire from the computer.

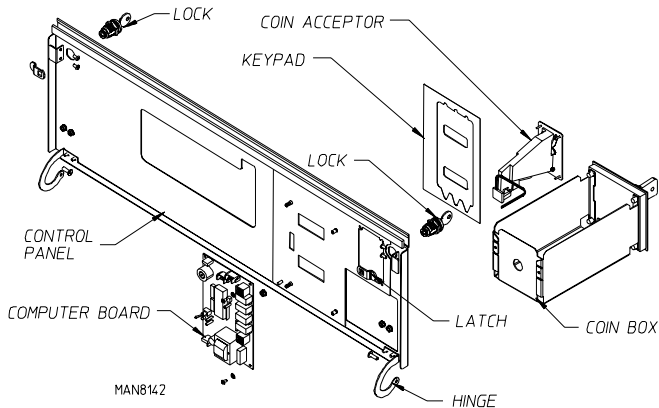

5. Disconnect the keypad ribbon from the computer.
6. Remove the two (2) screws securing the computer to the control panel and remove computer from panel, by pulling upwards on the corners.
7. Install new computer by reversing this procedure.
8. Be sure to check or reset programs.

NOTE: Use caution when handling the MP controller. It can be easily damaged by static electricity.

To Replace Keypad

1. Discontinue power to dryer,
2. Open control panel, unplug keypad ribbon from computer board.
3. Peel the keypad from the front of the control panel taking care to avoid scratching the panel.
4. Clean any adhesive residue from the panel.
5. Peel off paper backing from new keypad.
6. Align the display window on the keypad with the cutout in the control panel and press in place.
7. Connect keypad ribbon to the board and reconnect power to the dryer.
8. Test for operation by pressing each temperature selection.

To Replace Coin Acceptor

1. Discontinue power to dryer.
2. Open control panel (2 locks).
3. Swing control panel open.
4. Unplug optic switch harness connector.
5. Remove four nuts holding acceptor in place.
6. Pull coin acceptor out gently.
7. Reverse procedure for installing new acceptor.

To Remove Optic Switch

1. Disconnect power to dryer.
2. Open control panel (2 locks).
3. Swing control panel open.
4. Unplug optic switch connector.
5. Remove screw and washer holding optic switch to the coin acceptor and pull switch away.
6. Reverse procedure for installing new optic switch.

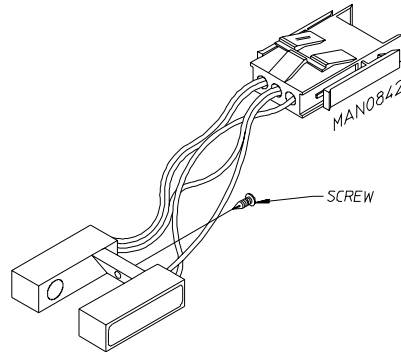

To Replace Computer Temperature Sensor Probe or Thermostat

1. Discontinue power to dryer.
2. Open control door/lint door.
3. Remove lint basket
4. Remove screws and pull sensor out.
 - a. Disconnect sensor harness connector from sensor.
 - b. Plug in the new sensor to harness and secure with two (2) screws.

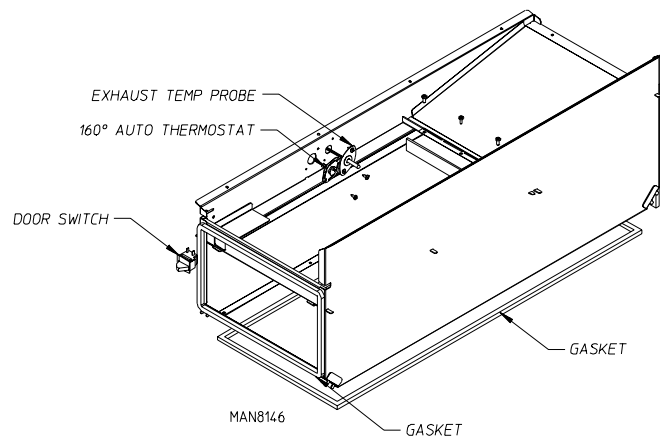

5. Reestablish power to dryer.

NOTE: If when the power is reestablished the computer display reads "dsfl", check for a loose connection on the wiring.

To Replace Motor Contactor 2-Pole, 24VAC

1. Discontinue power to dryer.
2. Remove top backguard.
3. To remove contactor, push towards the left then lift left side up to remove from panel.
4. Remove all wires from contactor (Note: make sure each wire is marked with location removed from).
5. Install new contactor in reverse procedure.
6. Reestablish power to dryer.

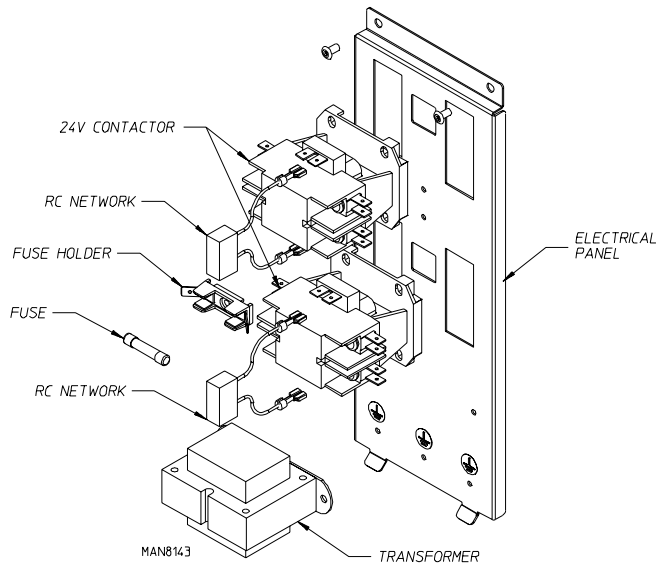

To Replace Gas Valve

1. Discontinue power to dryer
2. Close shutoff valve for machine. Remove the two wires on top of the gas valve.
3. Break and loosen union nut between shutoff and gas valve. Note: These components are extended to the machine.
4. Remove the four (4) screws holding the two pipe brackets on each side of the gas valve.
5. Remove gas valve from dryer.
6. Remove the orifice from the output side of the gas valve.

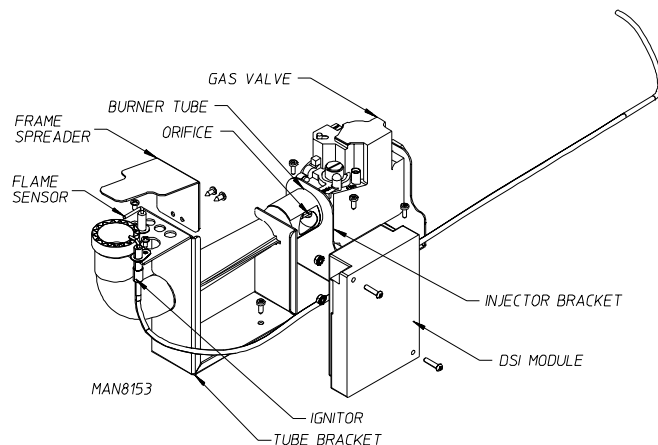

7. Reverse procedure for installing valve.

IMPORTANT: Pipe dope must be applied to the pipe feeding gas to the input side.

Replace Up-Shot Burner Tube Assembly (Refer to Illustration above)

1. Discontinue power to dryer.
2. Remove hex nut from the burner bracket this mounts the burner tube bracket to the gas valve plate.
3. Lift burner tube and bracket up over the weld stud.
4. Remove burner tube from bracket by sliding orifice side to the right and then push forward.
5. Reassemble new upshot burner tube assembly (P/N 880741) in reverse procedure.

IMPORTANT: Do not wrap the high voltage wire and flame probe wires together, improper operations may result. They may run alongside each other.

Make sure the gap from the ignitor to the top of the burner tube is 1/8" +/- 1/32".

To Replace Flame Sensor or Ignitor Probe

1. Discontinue power to dryer.
2. Refer to "Replace Upshot Burner Tube Assembly" steps 2 through 4.
3. If replacing flame sensor simply remove the screw and disconnect the connector on the flame sensor.
4. If replacing ignitor probe, remove screw, disconnect high voltage wire from DSI module and remove the probe and high voltage wire from the bracket.
5. Replace new item(s) in reverse procedure.

IMPORTANT: Do not wrap the high voltage wire and flame probe wires together improper operation may result. They may run alongside each other.

Make sure the gap from the ignitor to the top of the burner tube is 1/8" +/- 1/32".

To Replace Main Burner Orifice

1. Refer to "To Replace Upshot Burner Tube Assembly" and follow steps 1 through 4.
2. Unscrew main burner orifices and replace.

NOTE: Use extreme care when removing and replacing orifices. These orifices are made of brass and are easily damaged.

3. Reverse the removal procedure for reinstallation.

WARNING: Test all connections for leaks by brushing on a soapy water solution. Never test for leaks with a flame.

To Test and Adjust Gas (Water Column) Pressure

There are two types of devices commonly used to measure water column pressure. They are spring/mechanical-type gauges and manometers. The spring/mechanical-type gauge is not recommended, because it is easily damaged and not always accurate. A manometer is simply a glass or transparent plastic tube with a scale in inches. When filled with water and pressure applied, the water in the tube rises showing the exact water column pressure.

NOTE: Manometers are available from the factory by ordering P/N 122804.

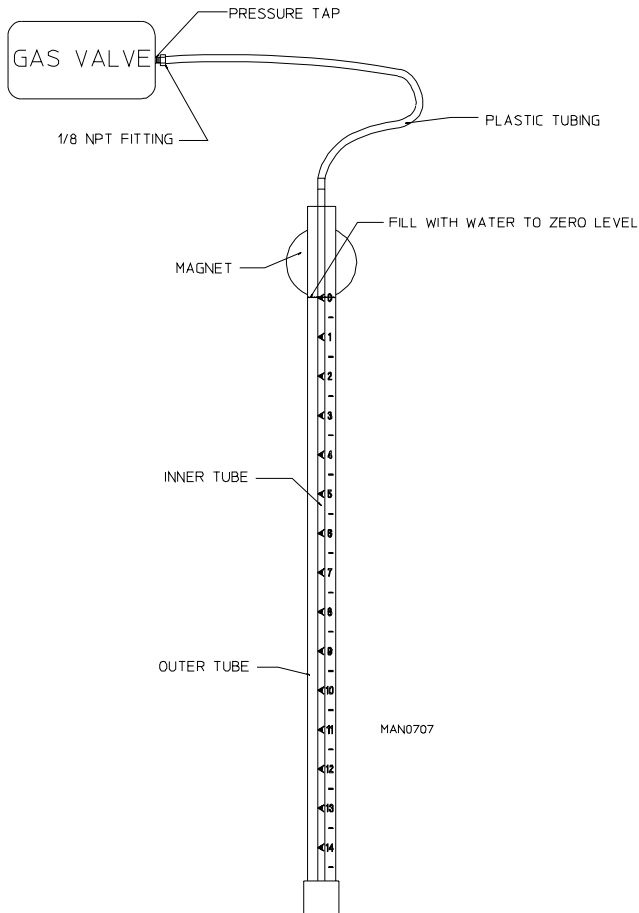

1. Test gas water column pressure.
 - a. Connect water column test gauge connection to gas valve pressure tap (1/8" N.P.T.). This pressure tap is located on the outlet (manifold) side of the valves.
 - b. Start dryer. With burner on, the correct water column reading in inches would be:

Natural Gas – 3.5 inches (8.7 mb) water column.
L.P. Gas – 10.5 inches (26.1 mb) water column.
2. To adjust water column pressure: for natural gas models remove vent cap. Turn the slotted adjustment screw located on top of the valve next to the terminals. Turn clockwise to increase manifold pressure and counterclockwise to decrease for L.P. gas models there is no regulator on valve.

NOTE: If correct water column pressure cannot be achieved, problem may be due to an undersized gas supply line, a faulty or underrated gas meter, etc.

To Convert from Natural to L.P. Gas

1. Discontinue electrical power to the dryer. (Both top and bottom pockets.)
2. Close all shutoff valves in the dryer gas supply line.
3. Remove back guard from dryer pocket to be converted.
4. Loosen and remove the screws that are holding the burner tube bracket to the cabinet (refer to figure below). Remove the gas burner tube and bracket from the dryer.

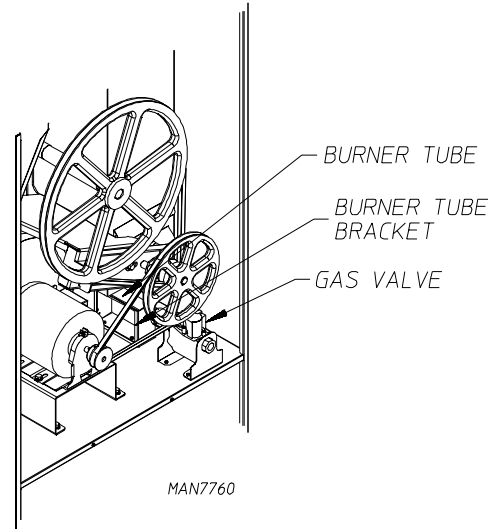

5. Unscrew main burner orifice and replace with the L.P. orifice provided.

IMPORTANT: Use extreme care when removing and replacing the orifice. The orifice is made of brass, which is easily damaged.

6. To convert the gas valve for use with L.P. gas, refer to the instructions included in kit envelope (#92-0737) supplied.
7. Reverse procedure for reinstalling the burner tube and bracket assembly to the dryer.
8. Beginning with step 3 repeat the procedure for the other pocket's burner assembly.
9. Affix L.P. conversion label to the dryer's data label as per instructions included in this kit.
10. Complete L.P. kit conversion label (ADC Part No. 114083) and affix this label as close as possible to the dryer's existing dryer rating (data) label/plate.
11. Affix L.P. conversion rating label (ADC Part No. 114090) as close as possible to the dryer's existing dryer rating (data) label/plate.
12. Open all shutoff valves (closed in Step #2), reconnect electrical power to the dryer, and test for leaks.

NOTE: Never test for leaks with an open flame!!! Use a soapy water solution or product intended for that purpose.

13. Replace all back guards securely.

To Replace DSI Module

1. Discontinue power to the dryer.
2. Remove the wires connected to the terminal strip at the bottom of the module.
3. Remove the high voltage wire from the module.
4. Remove the four (4) pal nuts securing the module to the modular mounting bracket.
5. Replace the module by reversing process.

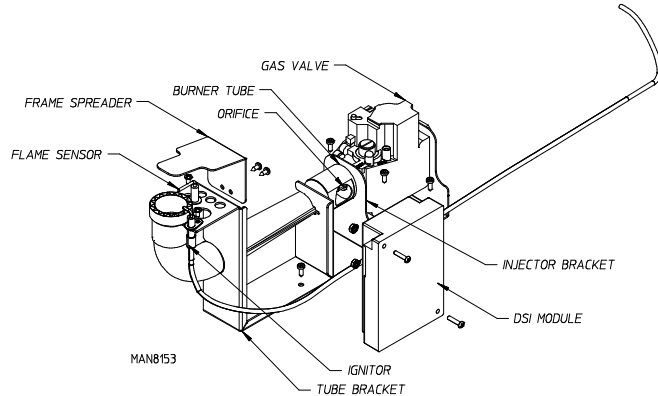

To Replace the Hi-Limit Thermostat (330°)

This thermostat is an important safety device serving as an added protection against failure of the air sail switch to open in the event of motor failure or reduced air flow conditions.

IMPORTANT: Under no circumstances should heat circuit safety devices ever be disabled.

1. Discontinue power to dryer.
2. Disconnect wires from hi-limit thermostat.
3. Loosen the two screws securing thermostat to the burner box.
4. Reverse procedure for installing new thermostat.

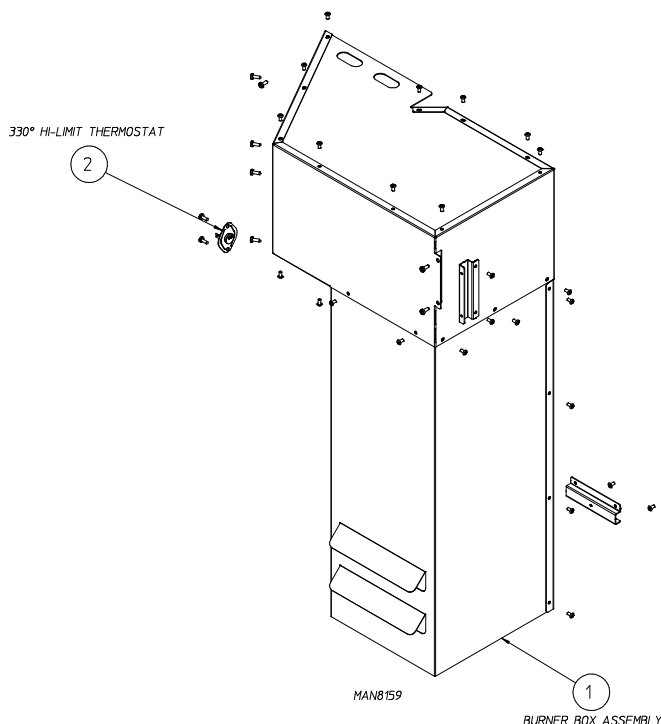

Sail Switch Assembly

The sail switch is a heat circuit safety device, which controls the heat circuit only. When the dryer is operating and there is proper air flow the sail switch damper pulls in and closes the sail switch, providing all the other heat-related circuits are functioning properly. If an improper air flow occurs, the sail switch damper will release, and the circuit will open.

IMPORTANT: Under no circumstances should heat circuit safety devices ever be disabled.

To Replace Sail Switch

1. Discontinue power to the dryer.
2. Remove the two (2) screws, which hold the sail switch box.
3. Disconnect the two (2) wires from the switch.
4. Disassemble sail switch from mounting bracket by removing the two (2) screws securing the switch in place.
5. Reverse this procedure for installing new sail switch. Adjust the sail switch as described in the next section.

To Adjust Sail Switch

1. Operate the installed dryer normally to verify that the heat system is fully operational.
2. Open the main dryer door.
3. Manually depress the door switch actuator.
4. While continuing to depress the door switch actuator, and with the door open, start the dryer.
5. If the heat system is not activated in 15-seconds, the sail switch is properly adjusted.
6. If the heat system is activated, the sail switch is improperly adjusted and must be readjusted by bending the actuator arm of the sail switch toward the front of the dryer. If the actuator arm is bent too far toward the front of the dryer, the dryer may not have heat when needed. After any adjustments of the sail switch, the above procedure must be repeated to verify proper operation.

CAUTION: Do not disable this switch by taping or screwing sail switch damper closed. Personal injury or fire could result.

Front Panel and Main Door Assemblies

To Replace Main Door Switch

1. Discontinue power to the dryer.
2. Open main door.
3. Remove door switch bracket and disconnect wiring from switch(es).
4. Remove the two (2) Phillips head screws holding the main door switch in place and replaced with new door switch.

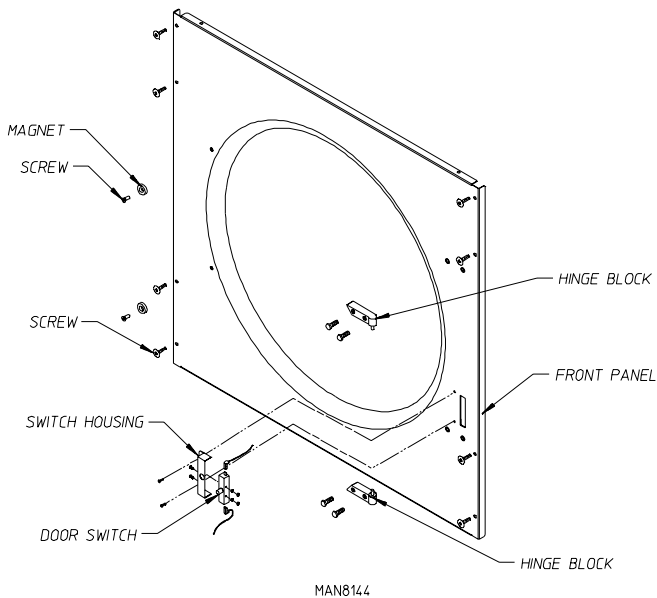

NOTE: Identify location of each wire for correct reinstallation.

IMPORTANT: Under no circumstances should the door switch be disabled.

To Replace Main Door Assembly

1. Remove screws holding main door upper hinge block.
2. Lift and remove door off of lower hinge block.
3. Reverse this procedure for reinstalling the new main door assembly.

To Install New Main Door Glass

1. Remove main door assembly from dryer (follow main door removal procedure).
2. Lay main door on a flat surface with front of door face down.
3. Remove glass and clean all old sealant off main door. This area must be completely cleaned for correct bonding.
4. Apply a narrow bead of silicone (P/N 170730) all around main door area where glass will rest.
5. Install glass on to door/adhesive and slightly pressed glass in place.

IMPORTANT: Do not press hard or silicone thickness between the glass and door will be reduced resulting in poor bonding.

6. The door assembly should now be put in an area where it will not be disturbed for at least 24 hours. Depending on the conditions, the curing time of the adhesive is 24 to 36 hours.
7. After 24 hours curing period, install main door on dryer by reversing the first step.

To Replace Front Panel

1. Discontinue power to dryer.
2. Follow procedure for removal of main door assembly.
3. Open control door (if replacing top panel).
4. Open lint door (if replacing bottom panel).
5. Remove the screws securing the front panel to the dryer.
6. Disconnect door switch wires from the connector.
7. Gently remove front panel assembly from dryer.

IMPORTANT: When removing front panel assembly be careful not to damage switch wires disconnect in step 6.

8. Reverse this procedure for installing new front panel.

Tumbler and Bearing Assembly

(Remove back guard to access assembly)

To Replace Tumbler Pulley

1. Disconnect power to dryer.
2. Remove back guard.
3. Loosen V-belts, then rotate pulley and roll V-belts out of grooves.
4. Loosen two (2) setscrews on the pulley and pull the pulley off the shaft.
5. Reverse procedure for installing new tumbler pulley.

NOTE: Check belt alignment before operating dryer.

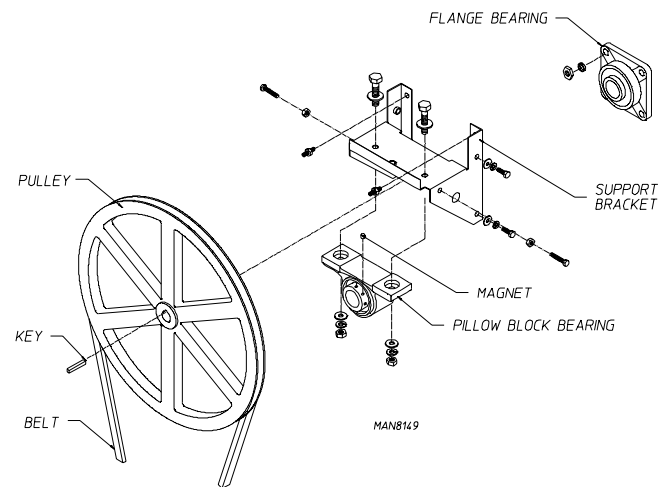

To Replace the Rear Tumbler Bearing

1. Disconnect power to the dryer.
2. Remove tumbler pulley (follow tumbler pulley removal procedure).
3. Remove the four (4) bolts securing the bearing box to the back of the dryer.
4. Loosen screws securing bearing to shaft.
5. Pull bearing box and bearing off of shaft.
6. Remove bolts securing bearing box and remove tumbler bearing.
7. Reverse procedure for installing new tumbler bearing.

NOTE: Check alignment of pulley before operating dryer.

To Replace the Front Tumbler Bearing

1. Discontinue power to dryer.
2. Remove tumbler pulley and bearing box (follow "To Replace the Rear Tumbler Bearing" steps 1 through 4).
3. Loosen setscrews on front tumbler bearing.
4. Using a wheel puller gently push the tumbler shaft towards the front tumbler bearing.

NOTE: An alternative method would be to place a block of wood on the end of the tumbler shaft and strike it with a heavy hammer. To prevent damage to the shaft the wheel puller method is preferred.

5. Remove the four (4) nuts securing the bearing to the dryer back and remove the bearing.
6. Reverse the procedure for installing new tumbler bearing.
7. Replace back guard.

Idler and Bearing Assembly

(Remove back guard to access assembly)

To Replace Idler Pulley

1. Remove back guard.
2. Loosen V-belts, then rotate pulley and roll V-belts out of grooves.
3. Loosen the two (2) setscrews on the pulley and pull off the shaft.
4. Reverse procedure for installing new idler pulley.

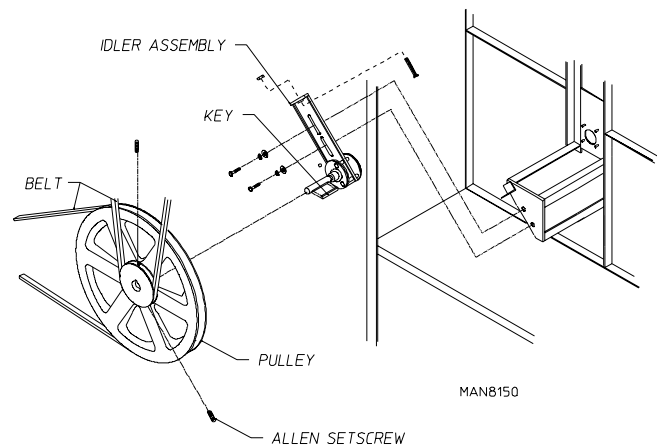

NOTE: Check the tension and alignment of belts before operating dryer.

To Replace Idler Bearing Assembly

NOTE: Idler shaft is pressed onto the bearing. If this is not done properly component failure could result. ADC recommends that the whole idler assembly be replaced (P/N 882777).

1. Remove idler pulley (follow "To Replace Idler Pulley").
2. Remove idler arm.
 - a. Remove two (2) bolts securing idler arm to the idler backup plate.
 - b. Remove idler arm assembly.
3. Reverse procedures for installing new idler bearing assembly.

NOTE: Check tensions and alignment of belts before operating dryer.

Tumbler

Tumbler Alignment (Vertical)

1. Discontinue power to dryer.
2. Remove back guard.
3. Loosen the four (4) hex head bolts on the sides of the bearing box (2 on each side).
4. Back off jam nuts on the two (2) Allen head adjustment screws.
5. Turn the screws clockwise evenly to raise the tumbler or counterclockwise evenly to lower the tumbler.
6. Rotate the tumbler from the front and check alignment with the main door opening.
7. Leave a large gap from the inside ring on the top of the front panel opening to the tumbler, and a smaller gap on the bottom to compensate for the weight of the clothes drying.
8. Tighten the four (4) hex head bolts on the sides of the bearing box, and the two (2) Allen head adjustment screws.
9. Replace back guard.
10. Reconnect power to dryer.

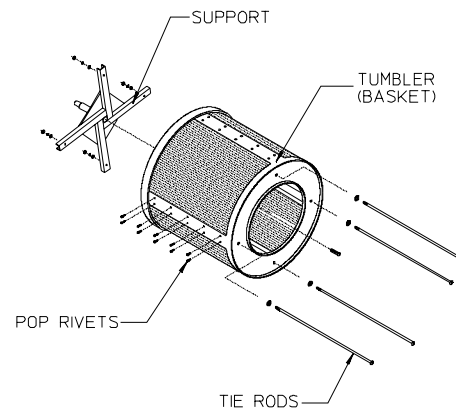

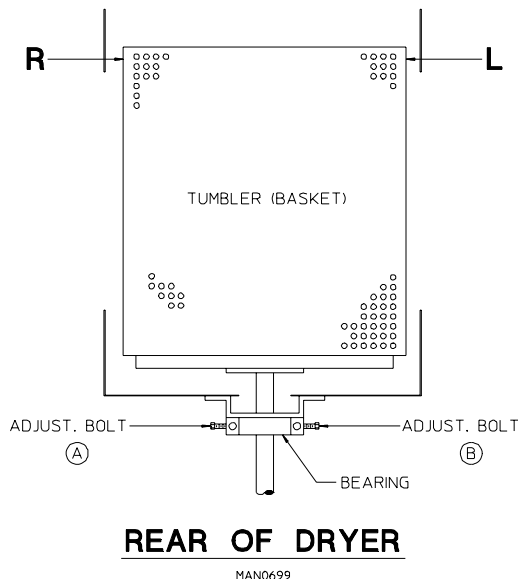

Tumbler Alignment (Lateral)

1. Discontinue power to dryer.
2. Remove back guard.
3. Loosen the two (2) hex head bolts, (one turn is enough), that holds the pillow block bearing to the bearing box.
4. Back off the two (2) jam nuts on the side adjustment bolts. Now rotate the tumbler from the front of the dryer, checking the space between the tumbler and front panel. This should be equal on the left-hand and right-hand side.
5. Lateral adjustment (viewing from the rear)
 - a. Loosening (by turning counterclockwise) the left-hand adjustment bolt and tightening (by turning clockwise) the right-hand adjustment bolt will shift the basket to the right.
 - b. Loosening (by turning counterclockwise) the right-hand adjustment bolt and tightening (by turning clockwise) the left-hand adjustment bolt will shift the basket to the left.
6. Tighten and secure both adjustment bolts and jam nuts.
7. Tighten the bearing box bolts.
8. Replace back guard and reestablish power to the dryer.

To Replace the Tumbler and/or Tumbler Support

1. Remove tumbler pulley and bearing box (follow "To Replace the Rear Tumbler Bearing" steps 1 through 4).
2. Remove front panel assembly (follow "To Replace Front Panel Assembly").
3. Loosen setscrews on front tumbler bearing.
4. Using a wheel puller gently push the tumbler shaft towards the front through the front tumbler bearing.

NOTE: An alternate method would be to place a block of wood on the end of the tumbler shaft and strike it with a heavy hammer. To prevent damage to the shaft, the wheel puller method is preferred.

5. Remove the tumbler and support through the front of the dryer.

- a. Loosen and remove the nuts and washers from the tumbler tie rods. Remove the rods.
 - b. Replace either tumbler or tumbler support by reversing the procedure.
6. Reassemble components into dryer by reversing steps 1 through 4.
 7. Check tumbler lateral and vertical alignment. Also, check belt tension and alignment.

NOTE: Check tension of belts and alignment of tumbler before operating dryer.

8. Replace back guard and reestablish power to dryer.

V-Belts

V-Belts should have proper tension. If too loose, they will slip, if too tight excessive wear on the bearing will result. If the pulleys are not properly aligned, excessive belt wear will result. Proper belt tension will allow 1/2" displacement under normal thumb pressure at mid span of the belt.

V-Belt Tension Adjustment – Tumbler to Idler

1. Loosen two bolts connecting to backup plate.
2. Back off jam nut on the adjustment bolt.
3. Tighten belts by turning adjustment bolt clockwise. (Turn counterclockwise to loosen belts.)
4. Tighten both bolts connecting to backup plate.
5. Check vertical plane of idler pulley for parallel alignment with tumbler pulley.
6. If realignment is required, loosen tumbler pulley and move tumbler pulley to proper position.
7. Retighten jam nut.

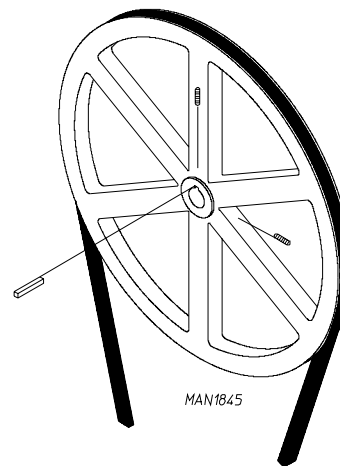

V-Belt Tension Alignment – Motor to Idler

1. Loosen two bolts connecting idler arm to backup plate.
2. Back-off on jam nut(s) on the adjustment bolt.
3. Loosen/tighten adjustment bolt to relax/increase belt tension.
4. Tighten adjustment bolt jam nut(s).
5. Tighten the two bolts loosened in step 1.

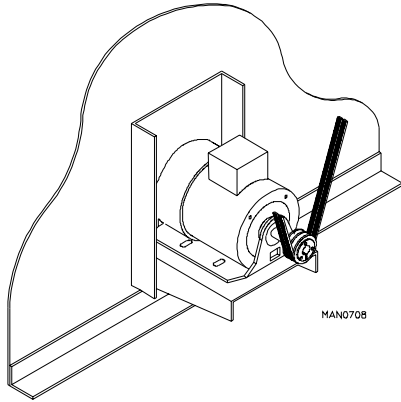

To Replace V-Belts

1. Loosen tension on V-belts, so that they can easily be rolled off pulleys.
2. Replace V-belts.
3. Retighten V-belts and adjust tension alignment per previous instructions.

Motor

To Replace Motor

1. Discontinue power to dryer.
2. Remove drive belt.
3. Disconnect wiring harness from motor.
4. Remove nuts and washers holding the motor mount to the base of the dryer and pull motor mount away.
5. Remove the two left-hand nuts on the motor shaft retaining the impellor. Work the impellor free from the motor shaft by means of a puller to prevent damage to the motor shaft.
6. Remove the bolts holding the motor and install new motor.
7. Remove pulley from old motor and install on new motor.
8. Align motor with impellor face in place with the motor mount at no less than 3/16" clearance.
9. Reassemble in the reverse of the above procedure.

Impellor

NOTE: Follow steps 1 through 5 and 8 in "To Replace Motor."

Lint Screen

To Replace Lint Screen

1. Slide lint screen out 3/4 of the way, reach through the access door and flip the hinge on the left side of the screen up.
2. Slide lint screen out along the lint coop track.
3. Reverse procedure for installing new lint screen.

Troubleshooting

The information provided will help isolate the most probable component(s) associated with the difficulty described. The experienced technician realizes, however, that a loose connection or broken or shorted wire may be at fault where electrical components are concerned – not necessarily the suspect component itself.

ELECTRICAL PARTS SHOULD ALWAYS BE CHECKED FOR FAILURE BEFORE BEING RETURNED TO THE FACTORY.

The information provided should not be misconstrued as a device for use by an untrained person in making repairs. Only properly licensed technicians should service the equipment.

OBSERVE ALL SAFETY PRECAUTIONS DISPLAYED ON THE EQUIPMENT OR SPECIFIED IN THIS MANUAL WHILE MAKING REPAIRS.

- A. No display on computer...
 1. Open circuit breaker switch or blown fuse.
 2. Bad wiring connection.
 3. Faulty microprocessor controller (computer).
- B. Computer will not accept touchpad entries...
 1. Touchpad ribbon is not plugged into computer securely.
 2. Touchpad is defective.
 3. Faulty microprocessor controller (computer).
- C. Dryer will not start, but computer display indicators are on...
 1. Failed contactor.
 2. Failed microprocessor controller (computer).
 3. Failed motor.
- D. Drive motor runs, burner is on, but tumbler will not turn...
 1. Broken, damaged or loose V-belt.
 2. Belts are contaminated (oil, grease, etc.).
 3. Loose or broken pulley.
- E. Drive motor runs, computer display heat indicator is on, but there is no heat...
 1. Lint coop automatic safety thermostat (160° F [71° C]) has failed.
 2. Sail switch is out of adjustment, has failed, or sail switch damper is not closing due to back pressure created by a restriction in the exhaust system.
 3. Failed burner hi-limit (330° F [166° C] for gas models) safety thermostat.
 4. Failed ignitor/flame-probe assembly or probe is misadjusted.
 5. Failed ignition DSI module.
 6. Failed gas valve.
 7. Failed microprocessor controller (computer).

- F. Dryer operates, probe sparks, but gas does not flow...
 1. Dryer gas shutoff valve is closed.
 2. Failed gas valve (open coil in valve).
 3. Loose wiring connection from DSI module to gas valve. (Check voltage at gas valve).
 4. Failed DSI module.
- G. Dryer operates, probe sparks but there is no ignition even though gas is evident...
 1. Gas pressure is too low. Check manifold pressure and take necessary corrective action.
 2. Ignitor probe is out of adjustment (readjust within gas flow).
 3. Lint accumulation in burner tubes.
- H. Dryer operates but is taking too long to dry...
 1. An inadequate exhaust ductwork system.
 2. Restriction in exhaust system.
 3. Insufficient make-up air.
 4. Poor housekeeping. Dirty or clogged lint screen.
 5. Extractors (washers) are not performing properly.
 6. An exceptionally cold/humid or low barometric pressure atmosphere.
 7. The supply gas may have a low heating value, check with local gas supplier.
 8. Failed temperature sensor (temperature calibration is incorrect).
 9. Failed microprocessor controller (computer).
- I. Thermal overload for drive motor is tripping...
 1. Either an exceptionally low or high voltage supply.
 2. Motor bearing failure.
 3. Bearing failure in drive system.
 4. Motor vents are blocked with lint.
 5. Failed motor.
 6. Insufficient make-up air.
- J. Dryer is cycling on burner hi-limit safety thermostat...
 1. Insufficient exhaust ductwork, size or restriction in exhaust system.
 2. Insufficient make-up air.
 3. Lint screen needs cleaning.
 4. Damaged impellor (fan).
- K. Display reads "dSFL," dryer sensor circuit failure...
 1. Check 1/8-amp fuse on computer.
 2. Faulty microprocessor temperature sensor probe.
 3. Open circuit in either one (1) of two (2) wires leading from the sensor probe to the computer.
 - a. Connection at sensor bracket assembly connector.
 - b. Connection at computer harness connector.
 4. Faulty microprocessor controller (computer).

- L. Dryer does not start. Display reads "door"...
 1. Main door is open.
 2. Lint drawer is open.
 3. Faulty main door or lint door switch.
 4. Open circuit in either main door or lint drawer switch harnesses.
 5. Faulty 24V transformer.
- M. There is excessive vibration coming from the tumbler...
 1. Tumbler is out of adjustment.
 2. Loose or broken tie rod.
 3. Failed tumbler support.

Electrical Troubleshooting _____

The information provided will help isolate the most probable components associated with the difficulty described. The experienced technician realizes, however, that a loose connection or broken or shorted wire may be at fault where electrical components are concerned, not necessarily the suspect component itself.

ELECTRICAL PARTS SHOULD ALWAYS BE CHECKED FOR FAILURE BEFORE BEING RETURNED TO THE FACTORY.

The information provided should not be misconstrued as a device for use by an untrained person in making repairs. Only properly licensed technicians should service the equipment.

OBSERVE ALL SAFETY PRECAUTIONS DISPLAYED ON THE EQUIPMENT OR SPECIFIED IN THIS MANUAL WHILE MAKING REPAIRS.

Phase 5 System Diagnostics

All major circuits, including door, microprocessor temperature sensor, heat and motor circuits are monitored. The Phase 5 microprocessor controller (computer) will inform the user, via the L.E.D. display, of certain failure codes, along with indicators both in the L.E.D. display and the outputs of each relay, (and door switch circuit) to easily identify failures.

Diagnostic (L.E.D. Display) Failure Codes

"door" – Indicates door switch circuit is open.

Touchpad entry was made while main door or lint drawer is open, or

There is a fault in the door switch circuit (external of the Phase 5 microprocessor controller [computer]).

"dSFL" – Indicates a fault in the microprocessor temperature circuit.

If fault is detected in the microprocessor heat sensor circuit, the display will read "dSFL," and the tone (buzzer) will sound for approximately 5-seconds every 30-seconds until...

The problem is corrected, or

Power to the dryer is discontinued and the problem is then corrected.

IMPORTANT: The Phase 5 microprocessor controller (computer) has its own internal heat sensing circuit fuse protection located on the back side of the Phase 5 computer. If a “dSFL” condition occurs, check to see if this fuse has blown. If it has not, do not replace the entire Phase 5 microprocessor controller (computer), replace the fuse and do so with a 1/8-amp (Slo-Blo) fuse only.

NOTE: Once the Phase 5 microprocessor controller (computer) detects a problem in the heat circuit, it updates every 30-seconds. If the problem was a loose connection in this circuit which corrected itself, the “dSFL” condition would automatically be cancelled.

“SEFL” – Indicates rotational sensor circuit failure meaning that there is a fault somewhere in the tumbler rotation detection circuit, or the Phase 5 microprocessor controller (computer) program related to this circuit is set incorrectly in the active mode (SEn) where the dryer is not equipped with the optional rotational sensor and should be set in the nonactive mode (nSEn).

“Hot” – Indicates a possible overheating condition. The Phase 5 microprocessor controller (computer) monitors the temperature in the dryer at all times. If the microprocessor controller (computer) detects that the temperature in the dryer has exceeded 220° F (104° C), it will disable all outputs (shut the dryer down), the tone (bUZ) will sound for approximately 5-seconds, and the L.E.D. display will read “Hot” until the temperature has dropped to 220° F (104° C) or lower.

L.E.D. Display Indicators

The L.E.D. indicator dots located at the top portion of the L.E.D. display (as shown in the illustration below) indicate the Phase 5 microprocessor controller (computer) output functions while a cycle is in progress. These indicator dots do not necessarily mean that the outputs are functioning. They are only indicating that the function (output) should be active (on).

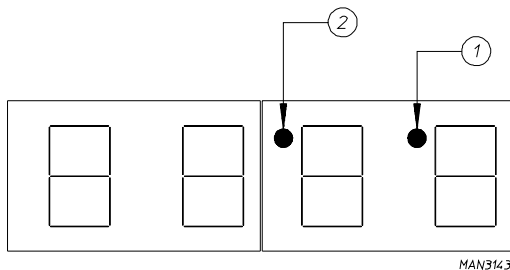

Blower Motor Circuit Indicator – Indicator dot is on whenever a cycle is in progress.

Heat Controller Indicator – Indicator dot is on whenever the Phase 5 microprocessor controller (computer) is calling for the heating circuit to be active (on).

Phase 5 Microprocessor Controller (Computer) Relay Output L.E.D. Indicators

There are three L.E.D. indicators (red lights) located at the back side area of the Phase 5 microprocessor controller (computer). These are identified or labeled in the illustration as “HEAT,” “MTR” (motor), and “DOOR.” These L.E.D.s indicate that the outputs of the Phase 5 microprocessor controller (computer), or, in the case of the door switch input, are functioning.

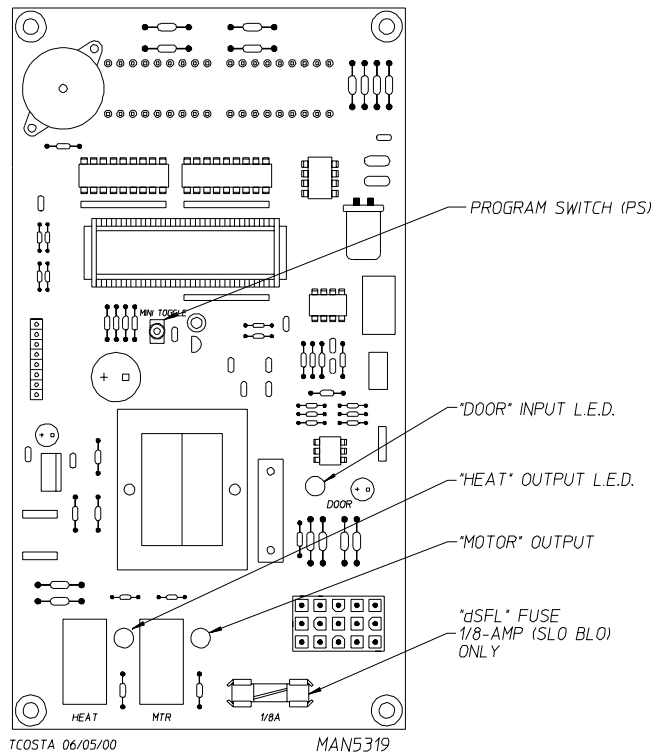

“DOOR” L.E.D. Indicator

SHOULD BE ON ALL THE TIME (even if the dryer is not running) unless the main door or lint drawer is open or there is a problem (open circuit) in the door switch circuit.

NOTE: If the dryer is started (display indicator dots are on) and there are no outputs (“HEAT” and/or “MTR” output L.E.D.s are off) and the “DOOR” input L.E.D. is on; then the fault is the Phase 5 microprocessor controller (computer) itself.

If the failure was elsewhere (i.e., the dryer’s door switch circuit), the L.E.D. display would read “door” if a keypad entry was attempted.

If the display indicator dots are on, and the “DOOR” L.E.D. input and the motor/heat output L.E.D.s are on, yet the motor and/or heat is not active (on); then the problem is elsewhere in the dryer.

“HEAT” Output L.E.D. Indicator

If the dryer is started and there is NO “HEAT,” yet the Phase 5 microprocessor controller (computer) display heat circuit indicator dot is on, but the “HEAT” output L.E.D. indicator is off; then the fault is the Phase 5 microprocessor controller (computer) itself.

If both the display indicator dot and the “HEAT” output L.E.D. indicator dot are on; then the problem (fault) is elsewhere (i.e., external to the Phase 5 microprocessor controller [computer]).

“MTR” Output L.E.D. Indicator

If the dryer is started and the blower (impellor/fan) motor is not operating, yet both the Phase 5 microprocessor controller (computer) display blower (impellor/fan) motor indicator dot and “DOOR” input L.E.D. indicator dot is off; then the fault is the Phase 5 microprocessor controller (computer) itself.

If the motor is not operating and the "MTR" output indicator is on; then the problem (fault) is elsewhere (i.e., external to the Phase 5 microprocessor controller [computer]).

Computer Logic and Wiring Diagram

Operator enters desired selection(s).

Information entered is sent to the microprocessor controller (computer) via the keypad.

The input information is sorted/processed and executed by the microprocessor controller (computer) chip.

The microprocessor controller (computer) output signal activates the contactors and DSI module which controls dryer functions.

NOTE: When contacting ADC with electrical questions, please have on hand the correct wiring diagram number for your particular dryer. This number is located on the top right-hand corner of the diagram. It is a six (6) digit number followed by a letter to distinguish the revision dates (refer to the illustration below).

The wiring diagrams used in Troubleshooting are specifically for dryers manufactured at the time of publishing. Your particular model may vary slightly depending on the date of manufacturing and options available. The correct wiring diagram and number is either taped to the rear of the control door on each dryer, or placed in the control box. If your particular diagram is lost or unreadable, call ADC with the serial number of the dryer. ADC will be more than happy to send you a diagram by fax or mail.

COMPUTER LOGIC AND WIRING DIAGRAM

